

INSTRUCTION MANUAL  
MODELS 503, 503C  
MILLIOHMMETERS

## CONTENTS

<u>Section</u>	<u>Page</u>
SPECIFICATIONS -----	iv
1. GENERAL DESCRIPTION -----	1
2. OPERATION -----	2
3. CIRCUIT DESCRIPTION -----	12
4. SERVICING -----	18
5. REPLACEABLE PARTS -----	24
SCHEMATIC -----	31

## ILLUSTRATIONS

Fig. No.	Title	Page
1	Front Panel. -----	1
2	Four Terminal Measurement. -----	2
3	Model 503 Controls. -----	5
4	Two-terminal Connection. -----	6
5	Modification for Unground Chassis. -----	7
6	Series Resistance Measurements. -----	9
7	Exploded View for Rack Mounting. -----	11
8	Power Supply Schematic Diagram. -----	12
9	Super Regulated 12 Volt Supply Schematic Diagram. -----	13
10	Test Current Generator Schematic Diagram. -----	14
11	AC Amplifier Schematic Diagram. -----	16
12	Synchronous Demodulator Meter - Output. -----	17
13	Waveform of Synchronous Demodulator. -----	19
14	Model 503 Internal Components Locations (Top Removed). ----	21
15	Location of Printed Circuit Board Components. -----	22
16	Location of Range Switch Components. -----	23

## SPECIFICATIONS

RANGE, ohms	Applied Current, milliamperes rms	Voltage Drop, microvolts rms	Maximum Dissipation in Sample, microwatts
0.001	100	100	10.0
0.003	33.0	100	3.3
0.01	10.0	100	1.0
0.03	3.30	100	0.33
0.1	1.0	100	0.10
0.3	0.33	100	0.033
1.0	3.0	3000	9.0
3.0	1.0	3000	3.0
10	0.30	3000	0.9
30	0.10	3000	0.3
100	0.03	3000	0.09
300	0.01	3000	0.03
1000	0.003	3000	0.009

**ACCURACY:**

**Meter:**  $\pm 1\%$  of full scale on all ranges.

**Output Terminals:**  $\pm 0.5\%$  of full scale on all ranges.

Note: Less than 1% error is added in measuring samples with a series reactance of 2% of sample resistance.

**ZERO DRIFT:** None.

**WARM-UP TIME:** 15 minutes.

**INPUT ZERO:** Lever switch prevents off-scale meter indications while changing samples.

**RISE TIME (10% to 90%):** 0.25 second on all ranges.

**SAFETY:** Maximum power dissipation in sample with improper range setting is 80 milliwatts. Maximum dissipation caused by instrument component failure and improper range setting is 160 milliwatts.

**REPEATABILITY:** Within 0.25% of full-scale range setting.

**CALIBRATION:** Internal resistance standard for calibration with front panel controls.

**RECORDER OUTPUT:**

**Output:** +100 millivolts dc at full scale.

**Output Resistance:** 800 ohms.

**Noise (above 10 Hz):** Less than 1 millivolt rms.

**CONNECTORS:** Test Leads: Cannon XLR-3-32. Output: Amphenol 80-PC2F.

**POWER:** 105-125 or 210-250 volts, 50-1000 Hz, 30 watts.

**DIMENSIONS, WEIGHT:** 5½" high x 17½" wide by 13½" deep; net weight, 18 lbs.

**ACCESSORIES SUPPLIED:** Model 5031 Current and Voltage Leads; mating output connectors.

## SECTION 1. GENERAL DESCRIPTION

The Model 503 Milliohmmeter permits rapid, accurate, low resistance tests. It combines a ruggedness and ease of operation not possible with bridges. Measurements are read directly on a mirror scale meter. Balancing is unnecessary, calibration stability is excellent, and the instrument is not damaged by overload.

Features include: 13 full-scale ranges from 0.001 to 1000 ohms; accuracy of  $\pm 1\%$  of full-scale meter indication and  $\pm 0.5\%$  of full-scale output voltage; no zero drift; rise time of 0.25 second to 90% of final value; sample dissipation of less than 10 microwatts; 100-millivolt dc output for chart recordings or control functions; and front panel calibration.

The measurement technique involves an ammeter-voltmeter method using an ac test current.

Typical uses include measurements of internal resistance of dry cells, resistivity profiles of thermo-electric materials; measurements of temperatures with thermistors; dry-circuit testing of contacts, and safe measurement of fuses and squibs.



## SECTION 2. OPERATION

2-1. APPLICATIONS: The Keithley Model 503 Milliohmmeter is especially useful for accurate measurement of low value resistors; resistances of lead wires, terminal connector contacts and welds; resistance change in conductors due to temperature and humidity effects; resistance of ohmic junctions in semiconductors; resistivity of semiconductors, contact resistance of vibrators, relays and choppers and internal resistance of dry cells. Also for resistivity profiles of thermoelectric materials and safe measurement of squibs and fuses.

### 2-2. MEASUREMENT TECHNIQUE:

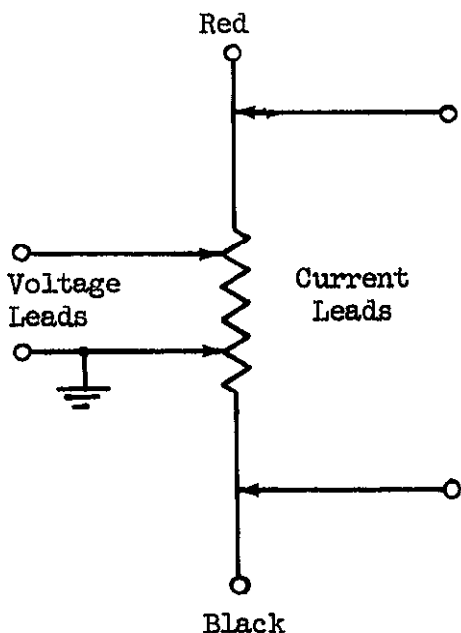

Figure 2

The Model 503 measures resistance by an ammeter-voltmeter method using an ac test current. Four terminals are employed; two furnish a known test current to the sample and two measure the resultant voltage drop. (Fig. 1) The voltage is measured by a synchronous ac voltmeter sensitive only to the test current frequency.

Most Kelvin resistance methods employ dc current to measure resistance. This method has the advantage of measuring only the resistive portion of the sample. However, due to the extremely low resistance being measured either extremely high currents must be passed through the sample or very high sensitivity dc voltmeter techniques must be used to measure the voltage drop across the sample. In the case of high current operation (which is the more common) excessive heating and damage to the sample may occur. If high sensitivity DC voltage measurement is used, extreme inaccuracy may occur because of thermal EMF's and other spurious dc disturbances. With the AC method used in the Model 503, there exists some possibility of error due to the reactive component

of the sample (Section 2-18) although in most cases at 40 cps testing frequency this is negligible. However, with an ac exciting test current, thermal EMF's are eliminated and very stable high sensitivity measurements can be made so that with this AC method sample dissipation can be held 10 microwatts in measuring a 1 milliohm sample.

A typical dissipation on a DC Kelvin Bridge is 1 watt for the same measurement.

2-3. ACCURACY: The accuracy of the measurement can be dependent on several factors. These are discussed in Section 2-18. The basic accuracy of the 503 is within 1% of full scale for meter indications and 0.5% for full scale output voltage.

2-4. REPEATABILITY: Having once established a reading for a particular sample measurement, it is possible to repeat within 0.25% of the full scale range setting. This assumes the connections to the sample remain fixed.

2-5. CALIBRATION: The 503 is self calibrating and thus reduces the need for resistance standards to check its accuracy. It is possible to verify the calibration with or without the sample attached to the test leads. (See Sect. 2-14)

2-6. VOLTMETER SPECIFICATIONS: Since the 503 uses a synchronous demodulator, the voltmeter is sensitive only to signals of the test current frequency. The sensitivity and input impedance are listed in Table 2.

TABLE 2

Ranges	Rms Input for Full Scale Deflection	Z in
Milliohm	100 uv	200 ohms
Ohm	3000 uv	$1 \times 10^6$ ohms

2-7. TEST CURRENT CHARACTERISTICS: The test current is a square wave derived from the transistor inverter. The frequency is about 40 cps, and can be adjusted as discussed in Section 3-2. This may be desirable if the power line frequency is a multiple of 40 cps.

The maximum open circuit voltage is no more than 20 volts peak to peak. No more than 80 milliwatts of power can be delivered from this source.

2-8. SPEED OF MEASUREMENT: Fast measurements are possible by virtue of an overall 0.25 second response (90% full scale) of the output voltage. A zero switch on the front panel shorts the input to the voltage amplifier, thus preventing off scale indication while changing samples. Recovery from overload is almost instantaneous and normal operation can be immediately resumed.

2-9. WARM-UP: Operation within the stated specification is assured if the 503 has a 15 minute period of warm-up. It can be used within one minute, but measurements may not be within the accuracy specification.

2-10. RECORDING: Output terminals are available at the rear of the instrument. The output is +100 millivolts across approximately 800 ohms. The output noise level, above 10 cps, is less than 1 millivolt rms. This output is suitable for driving digital voltmeters and servo-rebalance recorders. The accuracy of the output is 0.5% of full scale.

2-11. POWER REQUIREMENT: The Model 503 can be powered over a range of line frequencies from 50 cps to 1000 cps. The line voltages can range from either 105 to 125 volts or 210 to 250 volts. No special connections or modifications are required to operate over the range of power line frequencies.

A three prong power line cord is provided, this is to assure proper grounding of the instrument to the power line.

2-12. CABINET OR RACK MOUNTING: The Model 503 is shipped as a bench instrument unless the order calls for rack-mounting. The Model 4000 Rack Mounting Kit adapts the instrument for standard 19-inch rack mounting. Refer to paragraph 2-18 for conversion instructions.

2-13. DESCRIPTION OF CONTROLS AND TERMINALS:

1. RANGE SELECTOR: The RANGE SELECTOR has six milliohm positions ranging from 1 milliohm to 300 milliohms, and seven ohm positions ranging from 1 ohm to 1000 ohms. A CAL position is provided for instrument calibration. (Fig. 3)
2. ON: Toggle switch is the main power switch. Presence of power is indicated by the illuminated front panel pilot lamp. (Fig. 3)
3. OPERATE-ZERO: This is a lever switch. With the switch in the up (operate) position the 503 is ready to take measurements. In the down (zero) position the 503 is in zero check. (Fig. 3)
4. CALIBRATE: This control is used to calibrate the meter and the output voltage of the 503. It is a recessed slotted control that can be adjusted with a screw driver. (Fig. 3)
5. VOLTAGE TERMINALS: A 3-pin male receptacle is used for connection to the voltmeter circuit. Pin No. 3 is at chassis ground. Either test lead can be plugged into this receptacle. (Fig. 3)
6. CURRENT TERMINALS: A 3-pin male receptacle is used for connection to the current source. Either test lead can be plugged into this receptacle. (Fig. 3)
7. OUTPUT: A two terminal receptacle is located at the rear of the chassis. This provides the output voltage for recording. Pin No. 2 is at chassis ground.
8. RESET (503C ONLY): This unlocks the contact circuit. A 9-pin receptacle at the rear of the chassis provides connections for operation with the contact meter.
9. OUTPUT CAL: This is a slotted control located inside the instrument on the chassis behind the front panel. This adjusts the value of the output voltage for a full scale reading.
10. MILLIOHMS CAL: This is a slotted control located inside the instrument on the chassis behind the front panel. The milliohm ranges are calibrated using this control. A low resistance standard is required for its use. This is a factory adjusted control and should not require attention.
11. FUSE: A fuse extractor post is located on the rear of the instrument. For 117 volt operation use a 3 AG,  $\frac{1}{2}$  amp fuse; for 234 volts use a 3 AG,  $\frac{1}{4}$  amp.
12. POWER CORD: The three-wire cord with the NEMA approved three-prong plug provides a ground connection for the cabinet. An adapter to allow operation from two prong outlets is provided.



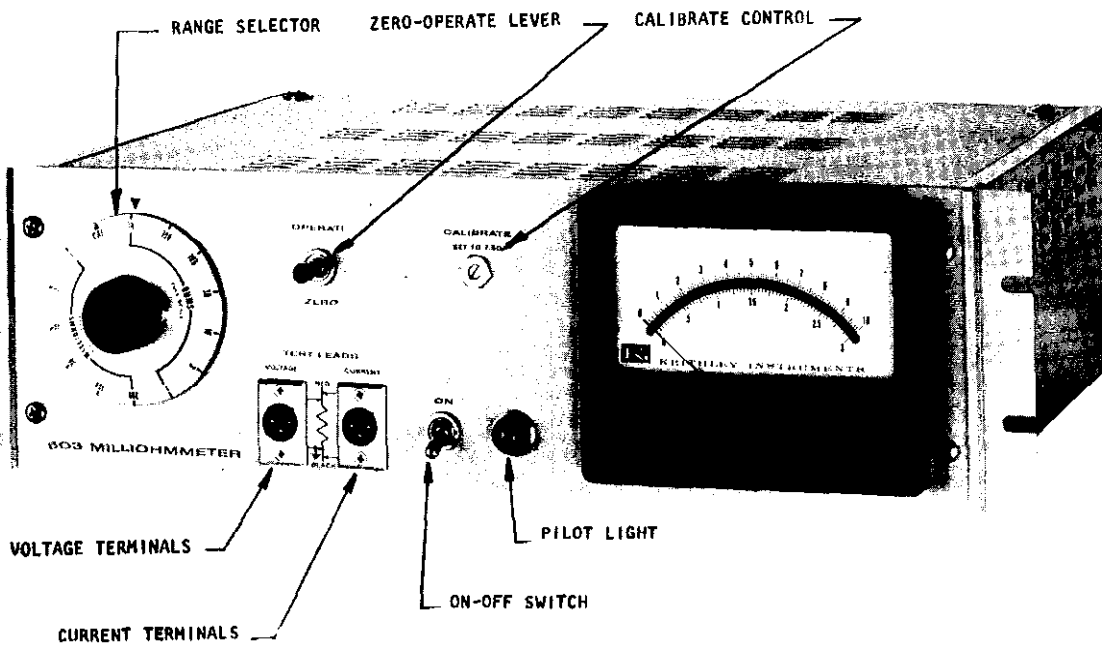

FIGURE 3. Model 503 Controls.

## 2-14. OUTLINE OF PROCEDURE:

1. Connect power cord to power source. A three-wire power cord is furnished with the 503. Power line voltage and frequency range are specified on the rear of the instrument.
2. Set ZERO-OPERATE lever to the ZERO position. Set RANGE SELECTOR to 1000-ohm position.
3. Turn on the power. Allow 15 minute warm-up.
4. CONNECTIONS: Each test lead set has two clips, one with a red insulator and the other with a black insulator. When making connections use both test leads, making sure clips with like color insulators are on the same side of the sample. (Refer to Figure 2) This is necessary to avoid meter readings below zero.
  - a. Four terminal connections: The current leads should be attached to the sample making sure the test current flows through the entire sample. This may include leads on the sample. Attach the voltage leads being sure they are connected only across that portion of the sample to be measured. If the terminals or the leads of the sample are included in the voltmeter circuit, their resistance will be included in the reading. (See Section 2-18)
  - b. Two terminal connections: This type connection is made by attaching together voltage and current clips having like color insulators and measuring across the sample. (Fig. 4) This type connection is permissible when measuring samples above 3 ohms. (See Section 2-18)

5. OPERATION: With the sample connected, set the ZERO-OPERATE switch to OPERATE, rotate the RANGE SELECTOR until a deflection is observed. Thus, if the RANGE SELECTOR is set at 100 milliohms and a reading of 6.3 is taken, the value of sample resistance is 63 milliohms.

If the sample is part of a system, attention should be given to the grounding of the sample. The voltage lead with the black insulator is the ground lead of the 503. (See Section 3-4)

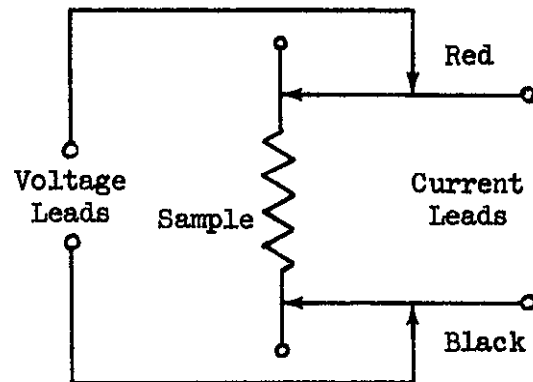

FIGURE 4. Two-terminal connection.

6. REMOVING THE SAMPLE: Place the OPERATE-ZERO switch in ZERO position and remove the sample.

2-15. CALIBRATION: Place the selector switch in CAL position. Set the OPERATE-ZERO switch to OPERATE position. Turn the slotted CALIBRATE control for needle deflection to 7.50 on the meter. The instrument can be calibrated independently of the test leads connected. (See Section 4-2.)

2-16. OUTPUT. Connect to the output terminals, observing that pin No. 2 is at ground. The 503 is designed to drive a 100 millivolt recorder. The CALIBRATE control on the front panel calibrates the output as well as the meter. An internal control R125 OUTPUT CAL is adjusted at the factory to insure tracking between the meter and the output voltage. (See Figure 14)

If it is desired to use a recorder other than 100 millivolts, the output terminals may be shunted with the following values:

Recorder Sensitivity	Resistance Value
50 mv	360 ohms
10 mv	80 ohms
1 mv	360 ohms
	(tap output 7 ohms from ground)

After the divider is added to the output, recalibrate the instrument on the CAL position. Adjust recorder sensitivity with R125, the internal recorder CAL control.

2-17. MEASUREMENT OF GROUNDED SAMPLES: It is possible that the test sample may be independently grounded at some point. Since the voltage test lead with the black clip insulator is at chassis ground, errors could arise in measurement.

1. TEMPORARY MEASURE FOR OCCASIONAL MEASUREMENTS: Isolate the Model 503 using a two-prong power cord adaptor to remove the ground connection to the power line. Place the instrument so that the cabinet is not touching ground. If the tilt bail is not used, the rubber feet can provide the proper insulation.

2. PERMANENT SET-UP: Should it be necessary to unground the chassis, (such as in rack use) the following modification will facilitate such measurement. The change allows the instrument to operate only on the milliohm ranges; the ohm ranges are inoperative.

Remove the chassis ground connection from pin 4 of T-1 and pin 3 of J-1. Then connect pin 3 of J-1 to pin 4 of T-1. In this way both the voltage and current test leads will be isolated from ground. (Fig. 5)

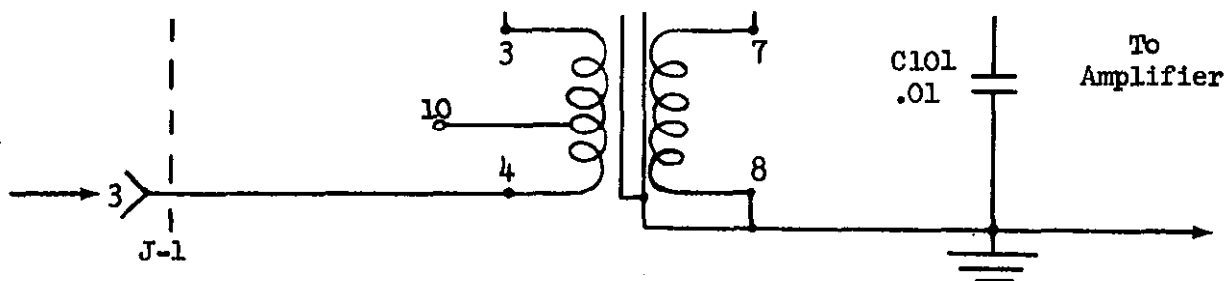

FIGURE 5. Modification for unground chassis.

## 2-18. ACCURACY CONSIDERATIONS:

1. MEASUREMENT IN THE PRESENCE OF DC CURRENTS: The 503 can measure resistance with dc currents present in the sample. An influencing factor is the amount of current that will saturate the voltmeter input transformer. A 1% error in measurements, using milliohm range settings, will occur if the dc current causes a 20 millivolt drop across the sample. The dc current through the sample can be increased if a capacitor is put in series with a voltmeter lead. The capacitor should be 10,000 ufd with a voltage rating greater than the dc current source voltage.

With measurements in the range from 1 ohm to 1000 ohms, a 1% error will occur if a current greater than 1 milliamperere flows through the current supply circuit. The voltmeter will not be effected unless the source voltage of the dc current exceeds 50 volts.

The dc sample current which will cause 1 ma to flow in the current supply circuit may be computed from the sample resistance and the range resistor in use.

2. INDUCTIVE AND CAPACITIVE EFFECTS: The Model 503 uses an ac measuring system and synchronous demodulation to discriminate against 60 cycle pick-up and to discriminate to a degree against reactive components in the sample. Therefore, usually, no special precautions or shielding are necessary unless the ac fields in the neighborhood of the sample are unusually strong. The usual cause of trouble will be due to electro-magnetic induction. Electro-static pick-up usually is no problem at the impedance involved. A good way to test for pick-up is to remove the current leads and leave the voltage leads attached to the sample. If no reading is seen, there is no cause of concern. If, however, there is a reading, the source of magnetic field must be removed or the sample oriented in such a way as to minimize the reading.

Because of the ac technique employed, inductive and capacitive components in the test impedance may cause some wave-form distortion and erroneous readings. In practice, it has been found that the following method will enable the user to calculate errors introduced by inductance in series with the sample or capacitance across it. Experimentally it can be shown that the error due to a series inductance or shunting capacitance is equal to about 50% of what would be calculated, assuming the shunting or series effect was due to the impedance computed for a 40 cps sine wave.

In the presence of large interfering ac fields, some needle flutter will be noted. This will be due to a beat between the 40 cps carrier frequency and the signal. The average value of the pointer indication will be the correct reading unless the interfering signal is exactly equal in frequency to the carrier. In this case large errors may be encountered. However, since a 40 cps interfering signal is rarely encountered, there will be little likelihood of trouble.

Coupling between the current and voltage leads can cause significant error on the 1 milliohm range. This can be minimized by keeping the voltage and current leads separated and by twisting the pairs of leads to reduce the enclosed area.

3. ERRORS DUE TO SERIES RESISTANCE IN CURRENT AND VOLTAGE LEADS: Series resistance may be appreciable in such cases as resistivity profile measurements, or when low resistance connections to the sample cannot be made. (See Fig. 6)

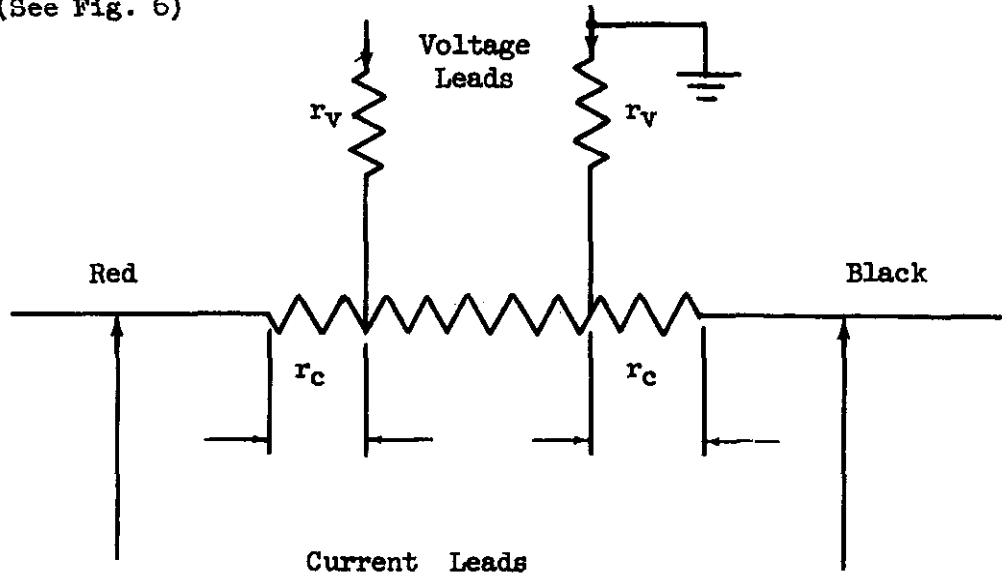

FIGURE 6. Series Resistance Measurements

TABLE 3

The tabulated values will give no more than 1% error in measurement:

Range	Total resistance in current leads $2r_c$	Total resistance in voltage leads $2r_v$
Milliohm range settings	1000x full scale range setting	1 ohm
Ohm range settings	33x full scale range setting	10K ohms

## 2-19. PREPARATION FOR RACK MOUNTING. (See Figure 7.)

1. The Model 503 is shipped for bench use with four feet and a tilt-bail. The Model 4000 Rack Mounting Kit converts the instrument to rack mounting to the standard EIA (RETMA) 19-inch width.

Item (See Figure 7.)	Description	Keithley Part No.	Quantity
1	Cover Assembly	14623B	1
2	Cover Assembly, Bottom (Supplied with Model 503)	14590B	1
3	Angle, Rack	14624B	2
4	Screw, Phillips Head, 10-32 UNC- 2x $\frac{1}{4}$ (Supplied with Model 503)	--	4
5	Front Panel (Supplied with Model 503)	--	1

TABLE 4. Parts List for Model 4000 Rack Mounting Kit.

2. To convert the Model 503, remove the four Phillips head screws at the bottom of each side of the instrument case. Lift off the top cover assembly with the handles; save the four screws. To remove the feet and tilt bail from the bottom cover assembly, turn the two screws near the back. The two pawl-type fasteners will release the cover and allow it to drop off. Remove the feet and the tilt bail and replace the cover (2).

3. Attach the pair of rack angles (3) to the cabinet with the four Phillips head screws (4) previously removed. Insert the top cover assembly (1) in place and fasten to the chassis with the two pawl-type fasteners at the rear. Store the top cover with handles, feet and tilt-bail for future use.

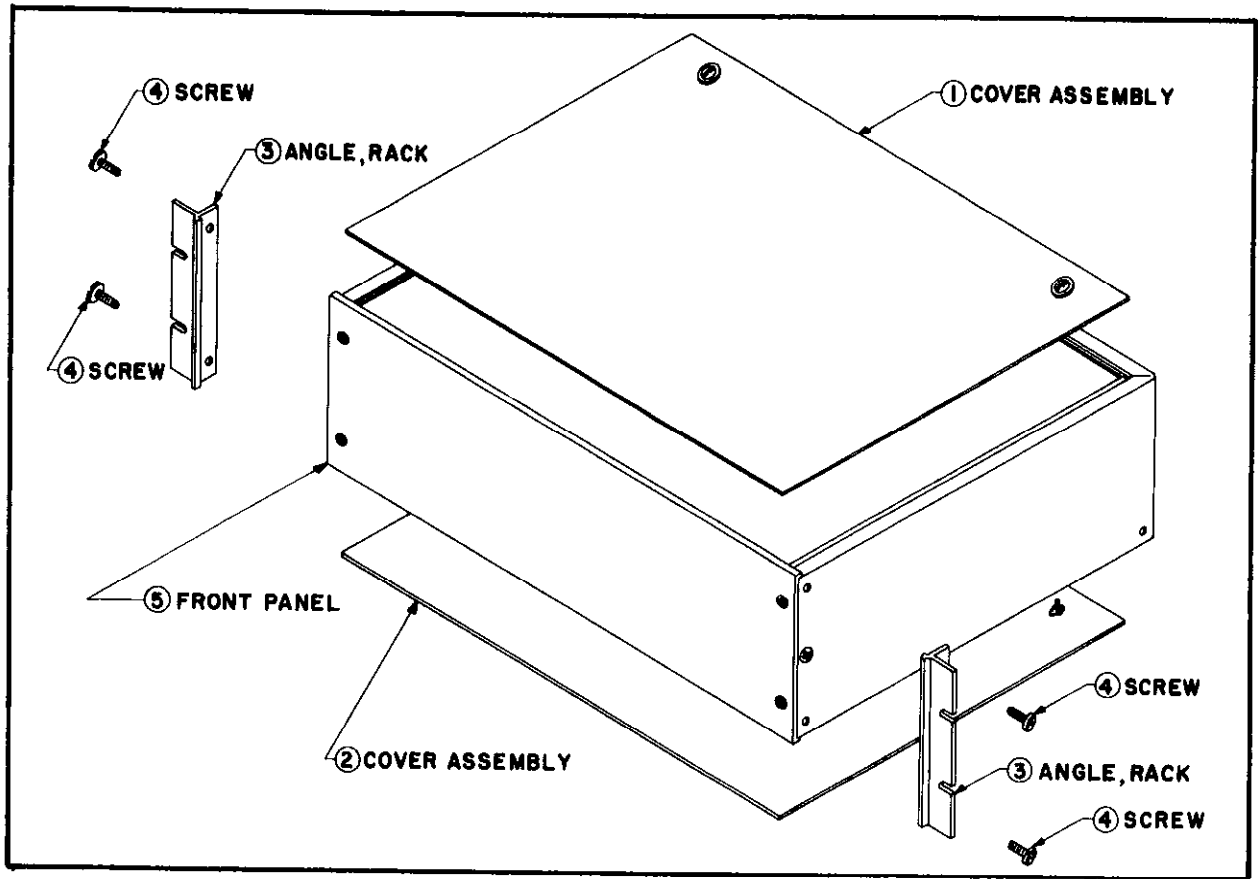

FIGURE 7. Exploded View for Rack Mounting.

### SECTION 3. CIRCUIT DESCRIPTION

The Model 503 circuit consists of four basic sections; a twelve volt super-regulated power supply, a transistor dc to ac inverter circuit, a four stage high gain vacuum tube amplifier and a silicon diode demodulator.

The twelve volt power supply operates from the line voltage and furnishes a very closely regulated 12 volts. This voltage is used to light the tube filaments and to operate the transistor converter. The converter operates at 40 cps. The output obtained from the converter transformer via various windings, operates the demodulator diodes, supplies the 40 cps test current and the B-plus supply for the ac amplifier via a rectifier-filter system.

The vacuum tube amplifier operates following an input transformer on the milli-ohm ranges and directly amplifies the signal on the ohm ranges. A high degree of gain stability is assured by a substantial feed-back factor and by the use of closely regulated plate and filament supplies.

The output of the amplifier is synchronously demodulated by a silicon diode bridge and the resulting dc signal operates the output circuit and the meter.

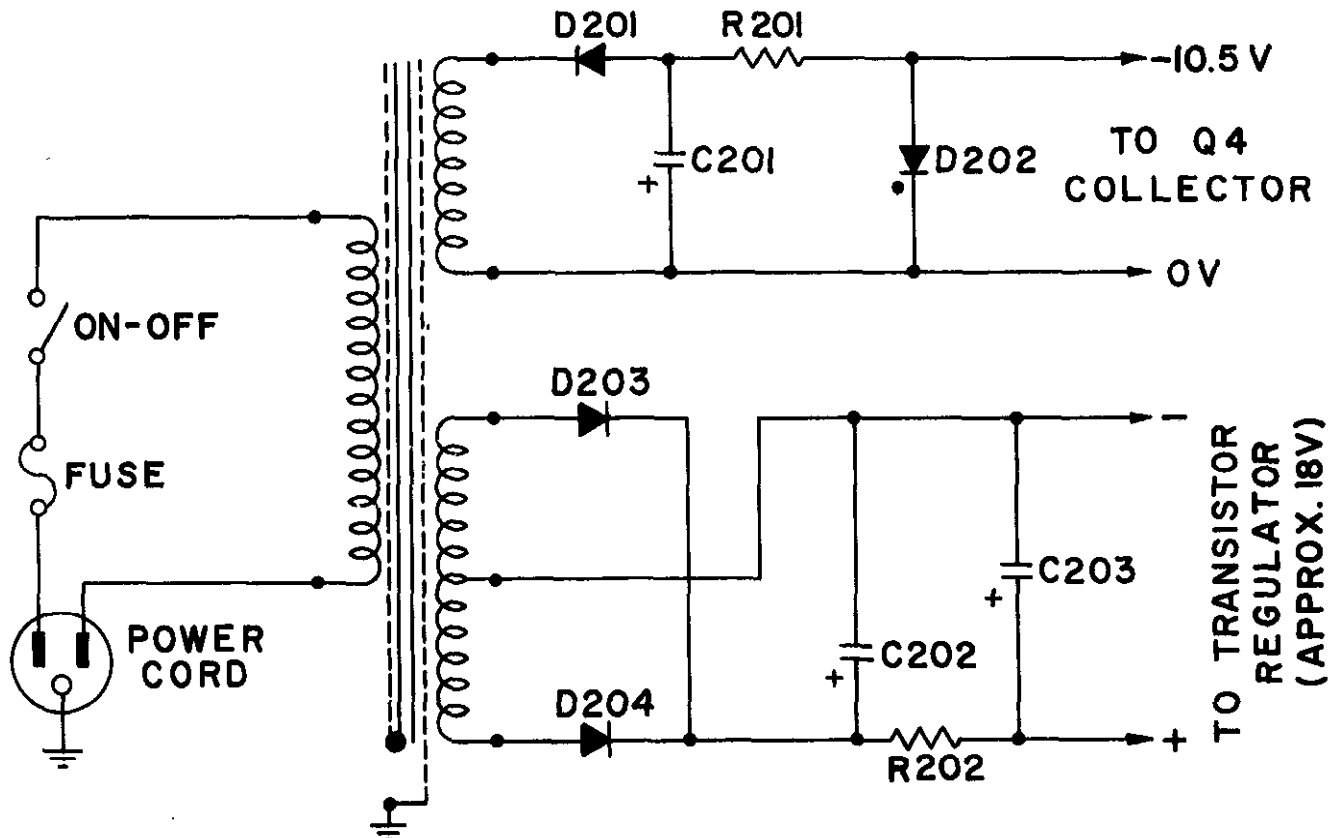

Figure 8. Power Supply Schematic Diagram



3-1. POWER SUPPLY: (Fig. 8) The power supply consists of three parts:

1. THE AC POWER TRANSFORMER AND FILTER-RECTIFIER CIRCUITRY: The power transformer, T-2, may be connected for either 117 or 234 volt operation as indicated in the schematic. The secondaries of the transformer supply 18 volts at 1 ampere and 117 volts at 5 ma. The output of the 18 volt winding is full-wave rectified by D203 and D204 and filtered by C202, C203 and R202. The dc voltage developed across C203 is approximately 20 volts. Neither terminal is grounded since the minus terminal of the regulator is grounded at the emitter terminal of Q1.

The output from the 117 v winding is half-wave rectified by D201 and filtered by C201. R201 is a dropping resistor for zener diode D202. This diode is connected between ground and the supply side of the load resistor for transistor Q4. The purpose of this connection will be discussed below.

2. THE SUPER-REGULATED 12 VOLT SUPPLY: (Fig. 9) The unregulated 20 volts dc obtained from rectifiers and the transformer is applied to a solid state regulator consisting of Q1 through Q6 and D202, D205, and D206. Q5 and Q6 form a differential amplifier which compares the voltage across the output of the regulator (C205 is across the output) via divider R210 and R209 to the voltage supplied by zener reference diode D205. If the voltages at the bases of Q5 and Q6 are not equal, the collector voltage of Q5 changes. This change is further amplified by Q4, Q3 and Q2. The signal is finally applied to the base of the series element in the regulator Q1. The signal is always of such magnitude and phase that output voltage is instantaneously brought back to 12 volts. RF-14 is a forward biased diode which sets the emitter voltage of Q4. The collector load resistor of Q4, R205, is returned to minus 10 volts supplied by zener, D202. This extra regulated voltage permits Q4

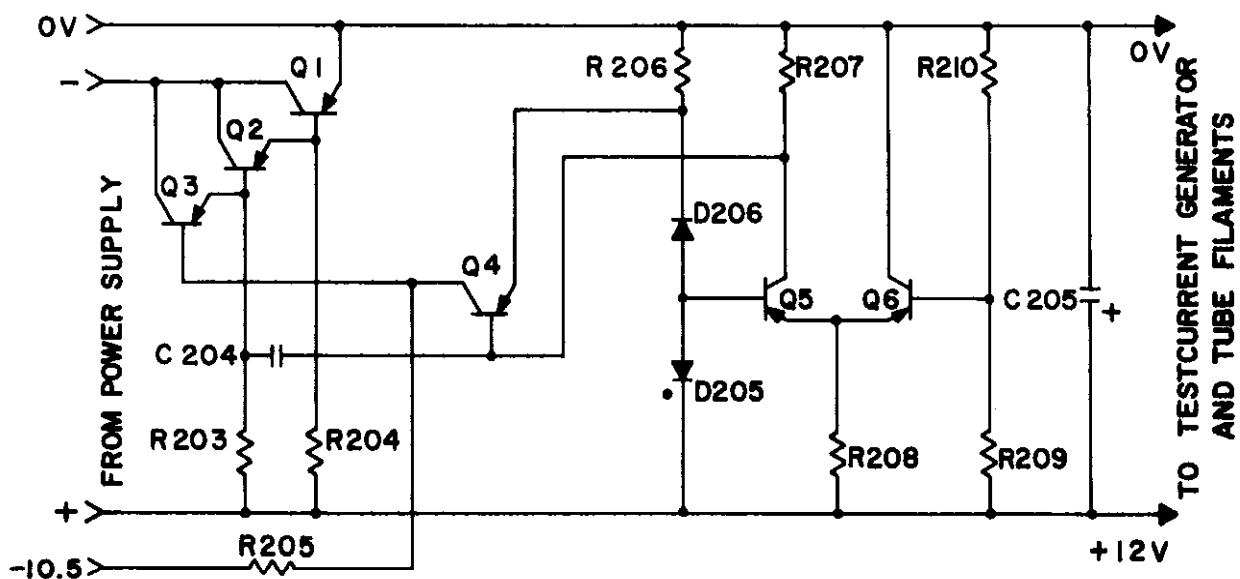

Figure 9. Super Regulated 12 Volt Supply Schematic Diagram

to operate at much higher gain than if the collector load were returned to the unregulated side of the supply and permits linear operation of Q4 with widely varying input voltages. This connection makes an important contribution to the performance of the power supply. Q3 and Q2 are cascaded emitter followers whose function is to increase the current gain of the series transistor, Q1. R203 and R204 are added to the circuit to provide stability at high temperatures since they make available a back-bias current equal to the leakage current of the series transistors at a temperature of approximately 80°C. C204 prevents high frequency oscillation of the power supply. The twelve volts at the output of the regulator powers the filaments of V1 and V2 and the pilot lamp DS-1.

3. 40 CPS TRANSISTOR STATIC INVERTER CIRCUIT: (Fig. 10) A portion of the regulated 12 volt power is also used as the supply for a dc converter consisting of the following parts: Transformer T3, transistors Q7 and Q8, diodes D207 and D208, capacitors C206 and C207, and resistors R211, R212 and R213. The operation is as follows: Transistors Q7 and Q8 are connected across the 12 volt supply through their emitters and the center-tap of the 12 volt winding of T3. The bases receive positive feed-back from another winding on T3. The phasing is such that one transistor is driven hard on while the other is cut off. This cycle lasts until the core of T3 reaches saturation. At this point the transformer can no longer keep the on transistor fully conducting and its collector current decreases. This causes the polarity of the feed-back winding to change and the transistor which was cut off now conducts and the conducting transistor is cut off. The frequency of oscillation is controlled by the transformer constants. In this case the frequency was picked to be 40 cps. The ten volts rms secondary winding is used to provide the test signal and provides a 20 volt peak-to-peak square-wave which is used with series resistors R128 through R139 to provide the proper test current for each range. Diodes D101 and D102 limit the output voltage when the current leads are open circuited.

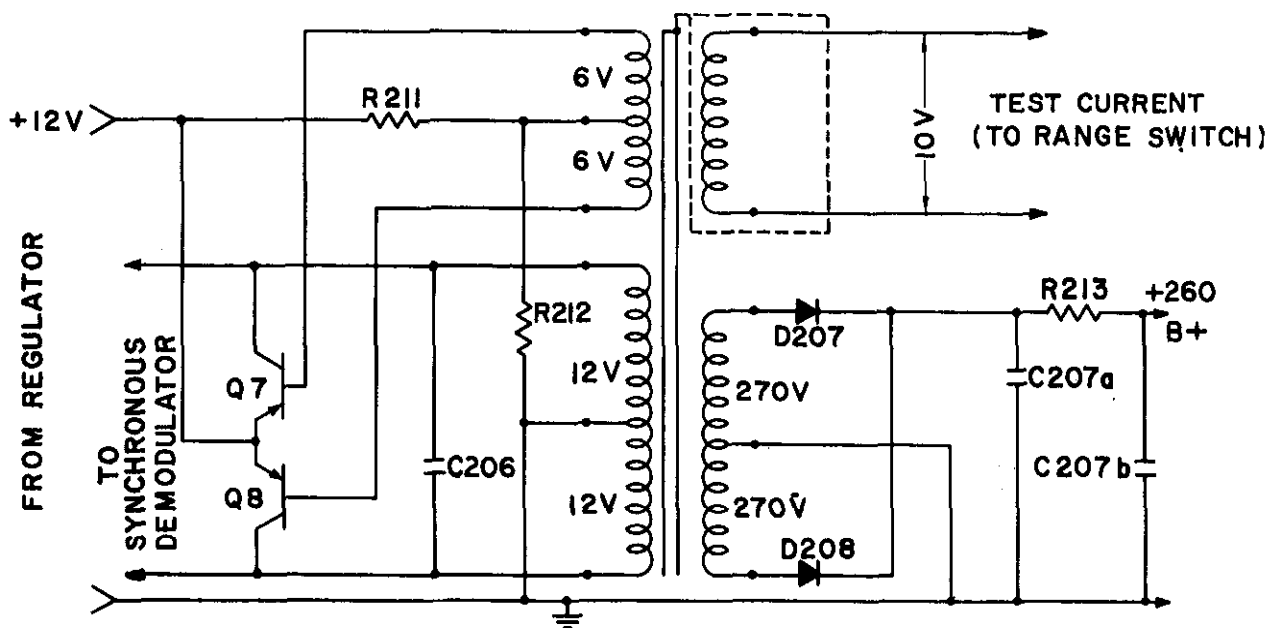

Figure 10. Test Current Generator Schematic Diagram

The 270 volt winding provides a B+ of 260 volts for the vacuum tube amplifier. The signal is rectified by D207 and D208 and filtered by C207 a and b' and R213.

Since the stability of the converter circuit depends only on the stability of the twelve volt power supply, very close regulation is obtained for all potentials used in the circuit. Consequently line voltage variations from 100 to 130 volts have no effect on the instrument.

3-2. TEST CURRENT GENERATOR: (Fig. 10) As mentioned above, the test current is derived from the 10 volt winding of T-3. Since Q7 and Q8 bottom on each half cycle, the amplitude stability of the signal depends only on the 12 volt supply, and is therefore as stable as the well-regulated 12 volt supply. The circuit is not particularly critical as to frequency or wave-form. However, a nearly perfect square-wave is generated and the frequency is stable to better than a few percent.

The current signal is varied to provide the change in range except between 300 milliohms and 1 ohm where the input transformer is removed from the circuit. The variation is accomplished by switching resistors R128 through R139 with each current range. R140 through R142 are used in conjunction with R128 to keep a constant load on the current source winding to insure a high order of accuracy. Diodes D101 and D102 limit the open-circuit voltage in the current leads to plus or minus 0.5 volts.

3-3. THE AC VACUUM-TUBE VOLTMETER: (Fig. 11) On the Milliohm Ranges the input signal passes through transformer T-1. This transformer has approximately a 70:1 step-up ratio and improves the impedance match between the voltage signal and the input grid by a factor of 5000:1. On the ohm ranges, where a larger signal is obtainable, the transformer is switched out so that its input impedance will not shunt the resistance being measured. Accordingly, on the Milliohm ranges, the input resistance is about 200 ohms. On the Ohms ranges, the input resistance is one megohm.

The input signal is fed into the input of the amplifier either through T1 or around it, depending on range, through S1, the OPERATE-ZERO switch. This switch is of the make-before-break variety to prevent switching transients. Following the switch is C102, the input blocking capacitor and R101, the input resistor of the feed-back network. R102 connects the feed-back signal to the input grid so that the input grid signal is the difference between the input signal and the feed-back signal or, as it is usually termed, the error signal. The error signal is amplified by a standard three stage ac amplifier consisting of V1 and V2a. V2b is an output cathode-follower which drives the feed-back loop, R118, R143, R114 and R115; and the meter and output circuits.

The gain of the amplifier is varied slightly to compensate for the absence or presence of the input transformer by shunting R114 and R145 across R143 in the Milliohm position. The MILLIOHM TRIM control is used to calibrate the milliohm ranges. The divided output of R118 and R143 through R145 is applied to R102 and returned to the input, completing the feed-back loop. A feed-back factor of 40 db assures high gain stability. The fact that all potentials used in the amplifier are closely regulated, also helps assure a high degree of gain stability and complete freedom from line bounce.

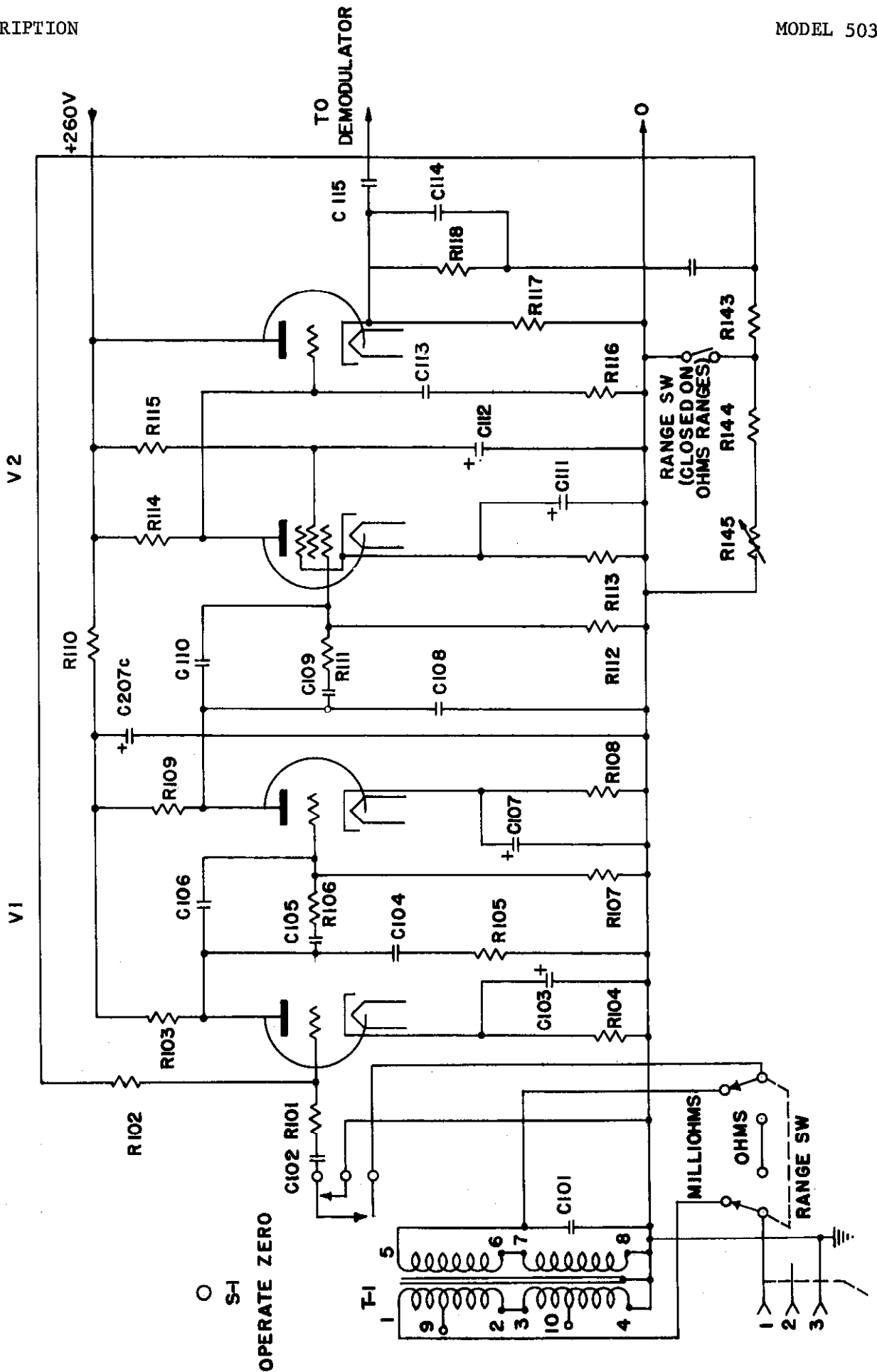

Figure 11. AC Amplifier Schematic Diagram

The amplifier is stabilized against low frequency oscillation by two sets phase-advance interstage couplings, C106, C105, R106 and R107 between the two halves of V1 and by C110, C109, R111 and R112 between V1b and V2a. Each network introduces an appropriate attenuation and phase lead to prevent oscillation and give adequate phase margin. C104, R105; C108; and C113 and R116; are individual high-frequency oscillation stoppers.

3-4. THE SYNCHRONOUS DEMODULATOR, METER AND OUTPUT: (Fig. 12) The output of V2b is coupled through C115 and R119 to a demodulator bridge circuit consisting of D103 through D106. The bridge is driven through R146 and R147 from the collectors of Q7 and Q8. Since the center tap of the collector winding is at ground, the drive signal is balanced to ground. When the junction of D103 and D105 is positive with respect to the junction of D104 and D106, the diodes are conducting and the junction between R119 and R120 is effectively grounded. When the polarity is reversed, the bridge is open circuited. Therefore, the signal is rectified in this manner. The output travels through R120, R121 and then is split. Part of the current drives the meter and the remainder the output. R121 is the calibration control. It is located on the front panel. On the CAL position of the range switch, R127 is switched in and this potentiometer is used to correct the meter reading if necessary. R125 allows calibration of the recorder terminal.

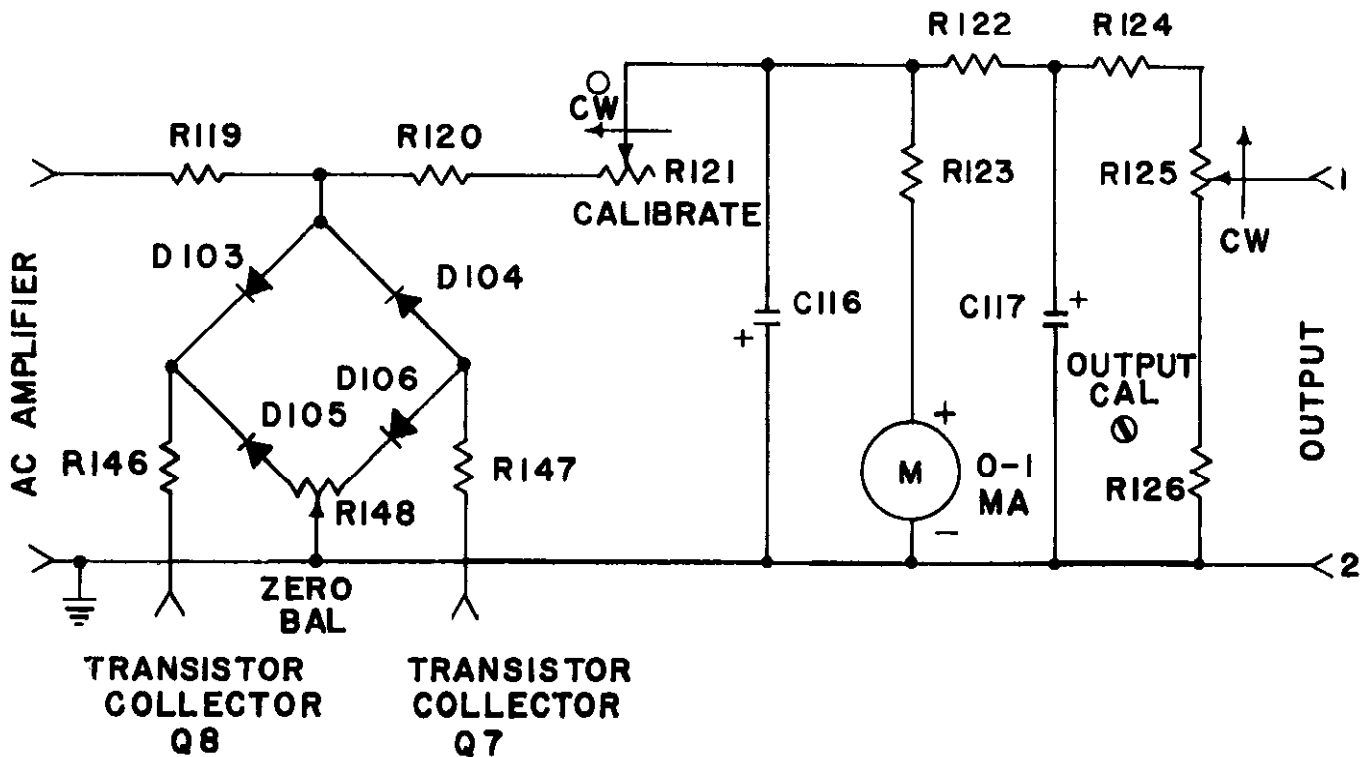

Figure 12. Synchronous Demodulator Meter - Output

## SECTION 4. SERVICING

The Model 503 should not require periodic maintenance. Occasional verification of the calibration (either section 2-14 or 4-2) and the dc balance (zero balance) should reveal any need for adjustment. If difficulty is encountered, read completely the following material:

### 4-1. Trouble Shooting Guide

Servicing is quite straight forward as the 503 employs only two vacuum tubes and eight transistors, all of which are conservatively operated within their ratings. No matched or critically selected components are used.

The usual caution should be observed when soldering to the printed circuit board as excessive heat will damage the board.

In servicing, bear in mind all operating voltages are obtained from the 12 volt transistor regulator, either directly or through the transistor inverter.

Reference should be made to Circuit Schematic DR 146280 for voltage values and other circuit parameters.

In case of complete failure to operate, the fuse, line cord and power source should all be checked. If these are all found satisfactory, use the following detailed service procedure to isolate the trouble:

#### 1. POWER SUPPLY:

- a. THE AC POWER TRANSFORMER AND FILTER RECTIFIER CIRCUITRY (Figure 8): Set the RANGE SWITCH to the 3 milliohm position with ZERO OPERATE switch in ZERO position. Remove transistor Q-1 from the circuit and measure the voltage across C203. (See schematic notes for recommended type VTVM). If approximately 25 volts dc is indicated, this portion of the circuit is in proper working order. Note that neither terminal of C203 is grounded.

Measure voltage across D202, which should be between -9 to -12 volts with respect to ground. If not, check diodes D201 and D202.

- b. THE SUPER REGULATED 12 VOLT SUPPLY (See Figure 9): Replace transistor Q-1 in the circuit. Determine that the regulated 12 volts across C205 does not vary more than 5 mv with line voltages from 105 volts to 125 volts. Use a variable autotransformer to supply the line voltage. (General Radio Variac).

If no voltage is present or the 12 volts are not regulated, check components in this portion of the circuit.

2. 40 CPS TRANSISTOR INVERTER (Figure 10): With the range switch set at 3 milliohms, connect the current test leads to an oscilloscope. Observe a 40 cps square wave with a peak to peak amplitude of about 20 volts. If this is present, measure +260 volts dc across C207b. If no square wave is observed, or the B+ is absent, check the components in this portion of the circuit.

NOTE: FOR SECTIONS 3 AND 4 THE RANGE SWITCH SHOULD BE IN CAL POSITION WITH THE ZERO-OPERATE SWITCH IN THE OPERATE POSITION.

3. THE AC VACUUM TUBE VOLTMETER. (Figure 11): Be sure both vacuum tube filaments are heated and the pilot lamp is lit. Since the pilot lamp is in parallel with the filament of V1 and the combination is in series with the filament of V2 across the 12 volt regulator, some service information is provided by its brilliance. If it lights normally, it may be assumed the supply is working properly. If it is brighter than normal, V1 is probably burned out. If the lamp is not lit, either V2 is burned out, or the pilot itself is open. The instrument will operate without the pilot lamp, but since the life of V1 will be reduced, it should be replaced.

If it is determined the tubes are operating properly, proceed as follows: Measure at the junction of C102 and R101 a 4 millivolt peak to peak square wave. This indicates the test current is properly reaching the amplifier through the range switch. Should there be no signal, or one of improper magnitude, inspect the range switch for faulty operation or component failure.

Next, check the voltage between pin 8 of V2 and ground. This should be a square wave voltage of about 10 volts peak to peak. A distortion in/or absence of this signal indicates a faulty AC amplifier.

4. SYNCHRONOUS DEMODULATOR - METER OUTPUT (Figure 12): Connect an oscilloscope to the junction of R-119 and R-120 and compare this wave form with Figure 13.

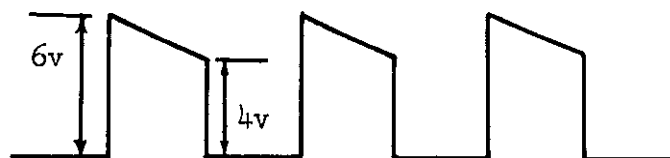

Figure 13

A distortion or absence of this wave form is an indication of a faulty demodulator.

4-3. CALIBRATION: The procedure of Section 2-14, calibrates the 503 on the 1000 range. Other ranges should be within specification once this range is properly calibrated. If the user wishes to further verify the CALIBRATION, or to calibrate for a given range or point, the following procedures are recommended:

1. OHM RANGES: A standard resistor of at least 0.05% accuracy is recommended. The standard should be selected to 3/4 of full scale of range in question, or to the value of the measurement to be made. The slotted control on the front panel will adjust the meter needle for proper deflection.
2. MILLIOHM RANGES: To calibrate the milliohm ranges, an appropriate low value standard resistor is required. Leeds & Northrup Type 4221-B, 100 milliohms; Type 4222-B - 10 milliohms; and Type 4223-B, 1 milliohm are all suitable. Using one of these resistors or their equivalent, adjust the "MILLIOHM CAL" (Figure 14) for the proper meter reading.



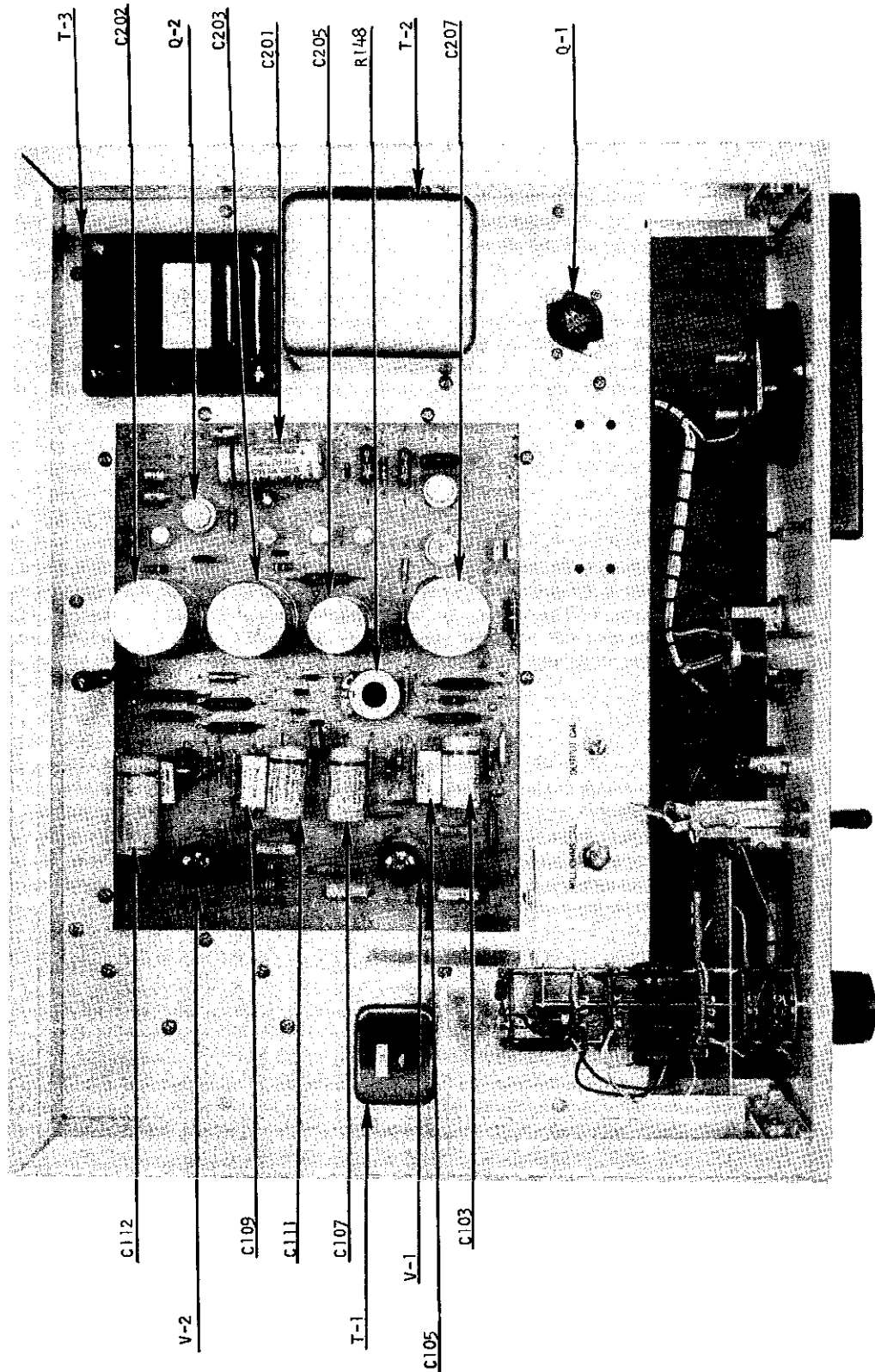

FIGURE 14. Model 503 Internal Components Locations (Top Removed).

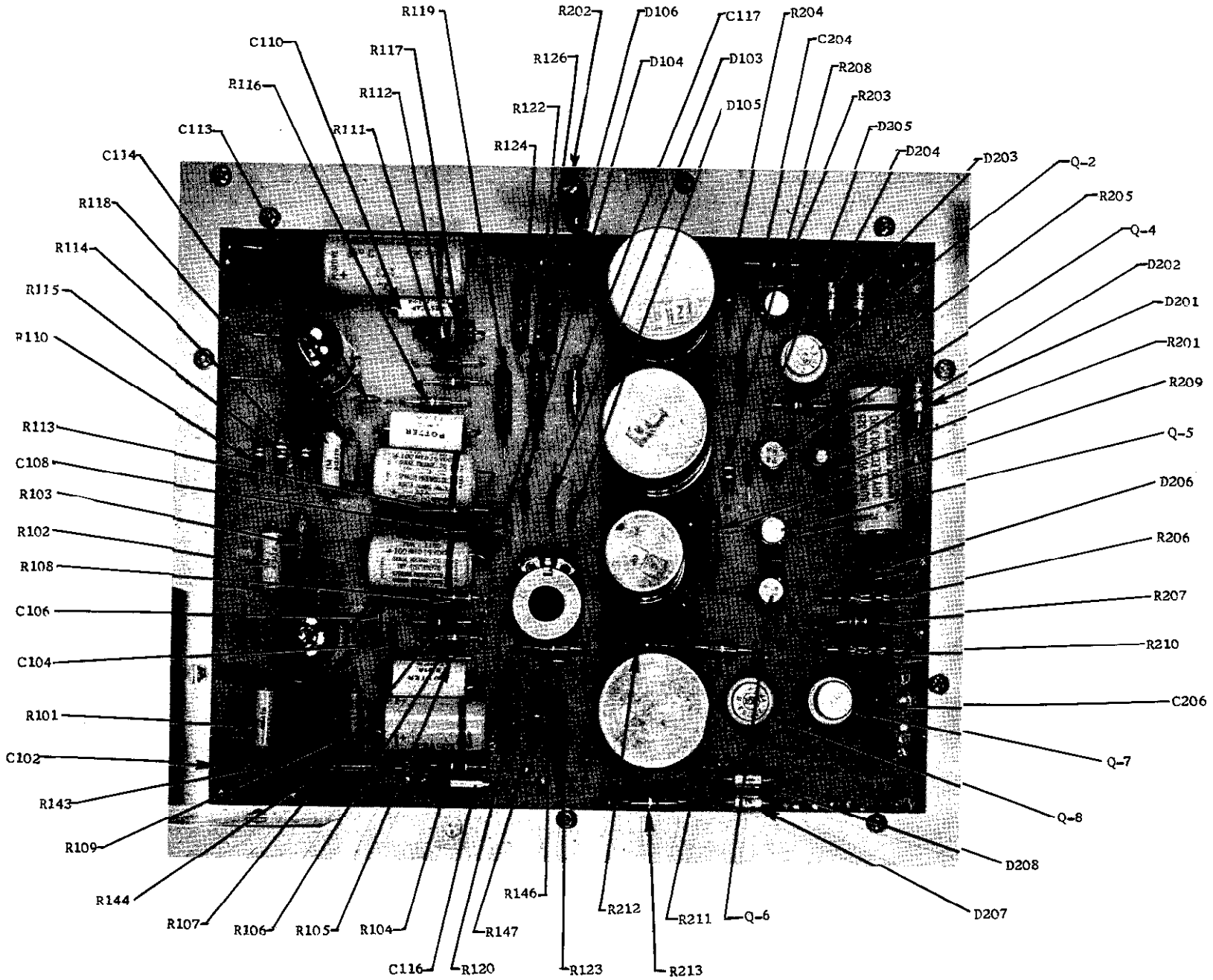

FIGURE 15. Location of Printed Circuit Board Components

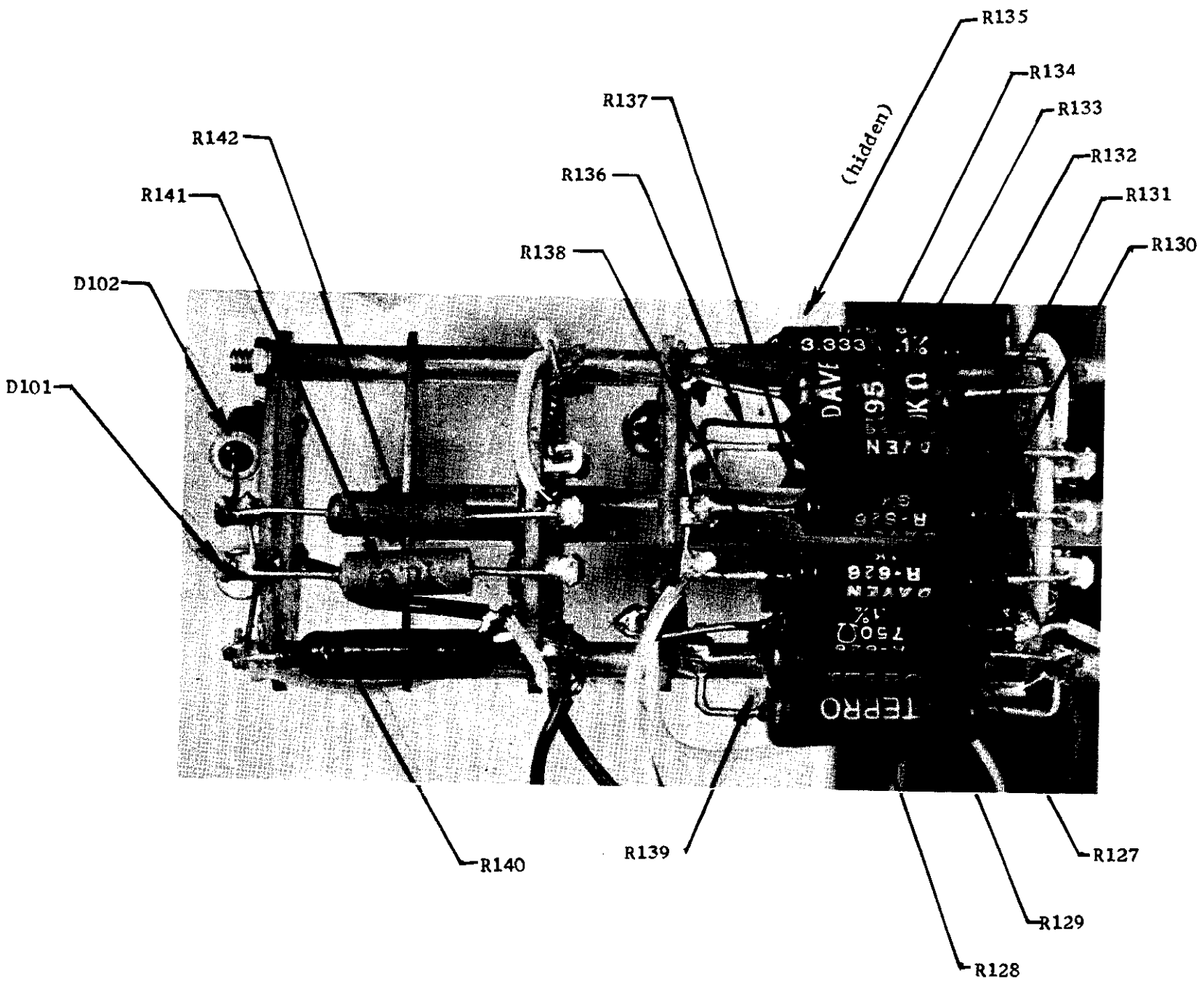

FIGURE 16. Location of Range Switch Components

## SECTION 5. REPLACEABLE PARTS

5-1. **REPLACEABLE PARTS LIST.** The Replaceable Parts List describes the components of the Models 503 and 503C Milliohmmeters and 5031 Current and Voltage Leads. The List gives the circuit designation, the part description, a suggested manufacturer, the manufacturer's part number and the Keithley Part Number. The name and address of the manufacturers listed in the "Mfg. Code" column are contained in Table 6.

### 5-2. HOW TO ORDER PARTS.

a. For parts orders, include the instrument's model and serial number, the Keithley Part Number, the circuit designation and a description of the part. All structural parts and those parts coded for Keithley manufacture (80164) must be ordered from Keithley Instruments, Inc. In ordering a part not listed in the Replaceable Parts List, completely describe the part, its function and its location.

b. Order parts through your nearest Keithley distributor or the Sales Service Department, Keithley Instruments, Inc.

amp	ampere	Mfg.	Manufacturer
CbVar	Carbon Variable	MtF	Metal Film
CerD	Ceramic, Disc	Mil. No.	Military Type Number
Comp	Composition	My	Mylar
CompV	Composition Variable	$\Omega$	ohm
DCb	Deposited Carbon		
EMC	Electrolytic, metal cased	p	pico ( $10^{-12}$ )
ETB	Electrolytic, tubular	$\mu$	micro ( $10^{-6}$ )
ETT	Electrolytic, tantalum	v	volt
f	farad	Var	Variable
k	kilo ( $10^3$ )	w	watt
M or meg	mega ( $10^6$ ) or megohms	WW	Wirewound
m	milli ( $10^{-3}$ )	WWVar	Wirewound Variable

TABLE 5. Abbreviations and Symbols.

MODELS 503, 503C REPLACEABLE PARTS LIST  
(Refer to Schematic Diagram 14628D for circuit designations.)

## CAPACITORS

Circuit Desig.	Value	Rating	Type	Mfg. Code	Mfg. Part No.	Keithley Part No.
C101	.01 $\mu$ f	50 v	My	84411	601PE	C41-.01M
C102	0.1 $\mu$ f	50 v	My	84411	601PE	C41-0.1M
C103	100 $\mu$ f	15 v	ETB	72699	TD100-15	C11-100M
C104	220 pf	1000 v	CerD	72982	831X5R221K	C22-220P
C105	1 $\mu$ f	200 v	My	13050	107-21	C66-1M
C106	.005 $\mu$ f	1000 v	CerD	72982	811Z5V502P	C22-.005M
C107	100 $\mu$ f	15 v	ETB	72699	TD100-15	C11-100M
C108	.02 $\mu$ f	1000 v	CerD	72982	841Z5V203P	C22-.02M
C109	1 $\mu$ f	200 v	My	13050	107-21	C66-1M
C110	.047 $\mu$ f	200 v	My	14655	WMF2S47	C66-.047M
C111	100 $\mu$ f	15 v	ETB	72699	TD100-15	C11-100M
C112	20 $\mu$ f	250 v	ETB	56289	TVA1508	C27-20M
C113	.002 $\mu$ f	1000 v	CerD	72982	801Z5V202P	C22-.002M
C114	270 pf	500 v	Mica	84171	DM15-271J	C21-270P
C115	10 $\mu$ f	200 v	PMC	72354	X10316	C69-10M
C116	56 $\mu$ f	6 v	ETT	05397	K56-J6KS	C70-56M
C117	56 $\mu$ f	6 v	ETT	05397	K56-J6KS	C70-56M
C201	20 $\mu$ f	250 v	ETB	56289	TVA1508	C27-20M
C202	500 $\mu$ f	50 v	EMC	14655	AA0160	C57-500M
C203	500 $\mu$ f	50 v	EMC	14655	AA0160	C57-500M
C204	.01 $\mu$ f	1000 v	CerD	72982	811Z5V103P	C22-.01M
C205	500 $\mu$ f	25 v	EMC	14655	AA0120	C58-500M
C206	0.22 $\mu$ f	50 v	My	84411	601PE	C41-0.22M
C207	40-40-20 $\mu$ f	450 v	EMC	56289	TVL3786	C33-40/40/20M

## DIODES

Circuit Desig.	Type	Number	Mfg. Code	Keithley Part No.
D101	Rectifier, 1A, 800V	1N4006	MOT	RF-38
D102	Rectifier, 1A, 800V	1N4006	MOT	RF-38
D103	Silicon	1N645	01295	RF-14
D104	Silicon	1N645	01295	RF-14
D105	Silicon	1N645	01295	RF-14
D106	Silicon	1N645	01295	RF-14
D107	Silicon	1N645	01295	RF-14
D201	Rectifier, 1A, 800V	1N4006	MOT	RF-38
D202	Zener	1N715	12954	DZ-22

## DIODES (Cont'd)

Circuit Desig.	Type	Number	Mfg. Code	Keithley Part No.
D203	Silicon	1N1563A	04713	RF-19
D204	Silicon	1N1563A	04713	RF-19
D205	Zener	1N936	04713	DZ-5
D206	Silicon	1N645	01295	RF-14
D207	Rectifier, 1A, 800V	1N4006	MOT	RF-38
D208	Rectifier, 1A, 800V	1N4006	MOT	RF-38
D209	Silicon	1N645	01295	RF-14

## MISCELLANEOUS PARTS

Circuit Desig.	Description	Mfg. Code	Keithley Part No.
DS-1	Pilot Light Assembly, Red lens (Mfg. No. 5100)	72765	PL-5R
---	Bulb, Miniature bayonet base (Mfg. No. 47)	08804	PL-4
F1 (117 v)	Fuse, 0.5 amp, (Mfg. No. 312.500)	75915	FU-6
F1 (234 v)	Fuse, 0.25 amp, (Mfg. No. 3120.25)	75915	FU-9
---	Fuse Holder (Mfg. No. 342012)	75915	FH-3
J1	Receptacle, VOLTAGE (Mfg. No. XLR-3-32)	71468	CS-71
J2	Receptacle, CURRENT (Mfg. No. XLR-3-32)	71468	CS-71
---	Jack, Mate of J1 and J2 (Mfg. No. XLR-3-11C)	71468	CS-72
J3	Receptacle, Microphone, OUTPUT (Mfg. No. 80PC2F)	02660	CS-32
---	Plug, Microphone, Mate of J3 (Mfg. No. 80MC2M)	02660	CS-33
J4 (c)	Receptacle, Output (Mfg. No. 126-221)	02660	CS-81
J5 (c)	Same as J4, but does not have jumper		
---	Plug, Mate of J4 and J5 (Mfg. No. 126-220)	02660	CS-82
K1 (c)	Relay, SPDT	80164	RL-3
M1 (a)	Meter	80164	ME-39
M1 (c)	Contact Meter	80164	ME-42
P1	Power Cord Set, 6 feet (Mfg. No. 4638-13)	93656	CO-5
---	Cable Clamp (Mfg. No. SR-6P-1)	28520	CC-4

(a) Used only on Model 503.

(c) Used only on Model 503C.

## MISCELLANEOUS PARTS (Cont'd)

Circuit Desig.	Description	Mfg. Code	Keithley Part No.
S1	Switch, SPDT, OPERATE - ZERO (Mfg. No. 3003DL)	82389	SW-59
S2	Rotary Switch less components, Range	80164	SW-114
---	Switch Assembly with components, Range	80164	14722B
---	Knob Assembly, Range Switch	80164	15363A
S3	Toggle Switch, DPDT, ON (Mfg. No. 20905-FR)	04009	SW-14
S4 (c)	Pushbutton Switch (Mfg. No. 202)	82389	SW-35
S5	Slide Switch	80164	SW-151
T1	Transformer, Input	80164	TR-53
T2	Transformer, Power	80164	TR-59
T3	Transformer, Inverter	80164	TR-55

## RESISTORS

Circuit Desig.	Value	Rating	Type	Mfg. Code	Mfg. Part No.	Keithley Part No.
R101	1 M $\Omega$	1%, 1/2 w	MtF	07716	CEC	R113-1M
R102	1 M $\Omega$	1%, 1/2 w	MtF	07716	CEC	R113-1M
R103	470 k $\Omega$	1%, 1/2 w	DCb	79727	CFE-15	R12-470K
R104	4.7 k $\Omega$	10%, 1/2 w	Comp	01121	EB	R1-4.7K
R105	12 k $\Omega$	10%, 1/2 w	Comp	01121	EB	R1-12K
R106	10 M $\Omega$	10%, 1/2 w	Comp	01121	EB	R1-10M
R107	1 M $\Omega$	10%, 1/2 w	Comp	01121	EB	R1-1M
R108	4.7 k $\Omega$	10%, 1/2 w	Comp	01121	EB	R1-4.7K
R109	470 k $\Omega$	1%, 1/2 w	DCb	79727	CFE-15	R12-470K
R110	15 k $\Omega$	10%, 1/2 w	Comp	01121	EB	R1-15K
R111	10 M $\Omega$	10%, 1/2 w	Comp	01121	EB	R1-10M
R112	1 M $\Omega$	10%, 1/2 w	Comp	01121	EB	R1-1M
R113	470 $\Omega$	10%, 1/2 w	Comp	01121	EB	R1-470
R114	100 k $\Omega$	10%, 1/2 w	Comp	01121	EB	R1-100K
R115	390 k $\Omega$	10%, 1/2 w	Comp	01121	EB	R1-390K
R116	10 k $\Omega$	10%, 1/2 w	Comp	01121	EB	R1-10K
R117	10 k $\Omega$	10%, 2 w	Comp	01121	HB	R3-10K
R118	1 M $\Omega$	1%, 1/2 w	MtF	07716	CEC	R113-1M
R119	1 k $\Omega$	1%, 1/2 w	WW	01686	E-30	R58-1K
R120	1.8 k $\Omega$	1%, 1/2 w	WW	01686	E-30	R58-1.8K

(c) Used only on Model 503C.

## RESISTORS (Cont'd)

Circuit Desig.	Value	Rating	Type	Mfg. Code	Mfg. Part No.	Keithley Part No.
R121	1 k $\Omega$	10%, 3 w	WWVar	37942*	R1000L	RP3A-1K
R122	2.5 k $\Omega$	1%, 1/2 w	WW	01686	E-30	R58-2.5K
R123	500 $\Omega$	1%, 1/2 w	WW	01686	E-30	R58-500
R124	2.5 k $\Omega$	1%, 1/2 w	WW	01686	E-30	R58-2.5K
R125*	200 $\Omega$	10%, 5 w	WWVar	71450	AW	RP3A-200
R126	700 $\Omega$	1%, 1/2 w	WW	01686	E-30	R58-700
R127	750 $\Omega$	0.1%, 1/2 w	WW	15909	1252	R70-750
R128	100.5 $\Omega$	10%, 1/2 w	WW	01686		R72-100.5
R129	301.5 $\Omega$	10%, 1/2 w	WW	01686		R72-301.5
R130	1 k $\Omega$	0.1%, 1/2 w	WW	15909	1252	R70-1K
R131	3 k $\Omega$	0.1%, 1/2 w	WW	15909	1252	R70-3K
R132	10 k $\Omega$	0.1%, 1/2 w	WW	DALE	MFF-10K	R-169-10K
R133	30 k $\Omega$	0.1%, 1/4 w	WW	15909	1195	R56-30K
R134	3.33 k $\Omega$	0.1%, 1/2 w	WW	15909	1252	R70-3.33K
R135	33.3 k $\Omega$	0.1%, 1/4 w	WW	15909	1195	R56-33.3K
R136	100 k $\Omega$	0.1%, 1/4 w	WW	DALE	MFF-100K	R-169-100K
R137	333.3 k $\Omega$	0.1%, 1/4 w	WW	DALE	MFF-333.3	R-169-333.3K
R138	1 M $\Omega$	0.1%, 1 w	WW	DALE	MFF-1M	R-169-1M
R139	3.33 M $\Omega$	0.1%, 1 w	MtF	07716	MEFT-8	R59-3.33M
R140	50 $\Omega$	1%, 1/2 w	WW	01686	E-30	R58-50
R141	11.1 $\Omega$	1%, 1/2 w	DCb	79727	CFE-15	R12-11.1
R142	3.33 $\Omega$	1%, 1/2 w	DCb	79727	CFE-15	R12-3.33
R143	500 $\Omega$	1%, 1/2 w	WW	01686	E-30	R58-500
R144	235 $\Omega$	1%, 1/2 w	WW	01686	E-30	R58-235
R145	100 $\Omega$	10%, 5 w	WWVar	71450	AW	RP3A-100
R146	1 k $\Omega$	10%, 1/2 w	Comp	01121	EB	R1-1K
R147	1 k $\Omega$	10%, 1/2 w	Comp	01121	EB	R1-1K
R148	100 $\Omega$	30%, 1/2 w	CompV	71450	45	RP12-100
R201	27 k $\Omega$	10%, 1 w	Comp	01121	GB	R2-27K
R202	1.5 $\Omega$	5%, 10 w	WW	94310	FR-10	R5-1.5
R203	10 k $\Omega$	10%, 1/2 w	Comp	01121	EB	R1-10K
R204	680 $\Omega$	10%, 1/2 w	Comp	01121	EB	R1-680
R205	10 k $\Omega$	10%, 1/2 w	Comp	01121	EB	R1-10K
R206	300 $\Omega$	1%, 1/2 w	WW	01686	E-30	R58-300
R207	3.9 k $\Omega$	10%, 1/2 w	Comp	01121	EB	R1-3.9K
R208	3.9 k $\Omega$	10%, 1/2 w	Comp	01121	EB	R1-3.9K
R209	900 $\Omega$	1%, 1/2 w	WW	01686	E-30	R58-900
R210	*300 $\Omega$	1%, 1/2 w	WW	01686	E-30	R58-300
R211	100 $\Omega$	10%, 1/2 w	Comp	01121	EB	R1-100
R212	1.5 k $\Omega$	10%, 1/2 w	Comp	01121	EB	R1-1.5K

\* Nominal value, factory set.



## RESISTORS (Cont'd)

Circuit Desig.	Value	Rating	Type	Mfr. Code	Mfr. Desig.	Keithley Part No.
R213	3.3 k $\Omega$	10%, 1 w	Comp	01121	GB-332-10%	R2-3.3K
R214	1 $\Omega$	1%, 1/2 w	DCb	79727	CFE-15-1 $\Omega$	R12-1
R215	2.2 k $\Omega$	10%, 1/2 w	Comp	01121	EB-222-10%	R1-2.2K
R216	1 $\Omega$	1%, 1/2 w	DCb	79727	CFE-15-1 $\Omega$	R12-1

## TRANSISTORS

Circuit Desig.	Mfr. Desig.	Mfr. Code	Keithley Part No.
Q1	2N1535	04713	TG-7
Q2	40319	02735	TG-50
Q3	2N1381	01295	TG-8
Q4	2N1381	01295	TG-8
Q5	2N1381	01295	TG-8
Q6	2N1381	01295	TG-8
Q7	2N5193	04713	TG-107
Q8	2N5193	04713	TG-107

## VACUUM TUBES

Circuit Desig.	Mfr. Desig.	Mfr. Code	Keithley Part No.
V1	7025	73445	EV-7025
V2	6U8	81453	EV-6U8A

MODEL 5031 REPLACEABLE PARTS LIST

Description	Mfr. Code	Keithley Part No.
Test lead, 48 inches	80164	14731B
Two Alligator Clips (Mfg. Series 60)	76545	AC-1
Jack (Mfg. No. XLR-3-11C)	71468	CS-72

01121	Allen-Bradley Corp. Milwaukee, Wis.	02660	Amphenol-Borg Electronics Corp. Broadview Chicago, Illinois
01295	Texas Instruments, Inc. Semi-Conductor-Components Division Dallas, Texas	02735	RCA Semiconductor and Materials Division of Radio Corp. of America Somerville, N. J.
01686	RCL Electronics, Inc. Riverside, N. J.	04009	Arrow-Hart and Hegeman Electric Co. Hartford, Conn.
04713	Motorola, Inc. Semiconductor Products Division Phoenix, Arizona	72982	Erie Technological Products, Inc. Erie, Pa.
05397	Kemet Co. Cleveland, Ohio	73445	Amperex Electronic Co. Division of North American Philips Co., Inc. Hicksville, N. Y.
07716	International Resistance Co. Burlington, Iowa	75042	International Resistance Co. Philadelphia, Pa.
08804	Lamp Metals and Components Department G. E. Co. Cleveland, Ohio	75915	Littelfuse, Inc. Des Plaines, Ill.
12954	Dixon Electronics Corp. Scottsdale, Arizona	76545	Mueller Electric Co. Cleveland, Ohio
13050	Potter Co. Wesson, Miss.	79727	Continental-Wirt Electronics Corp. Philadelphia, Pa.
14655	Cornell-Dubilier Electric Corp. Newark, N. J.	80164	Keithley Instruments, Inc. Cleveland, Ohio
15909	Daven Co. Livingston, N. J.	81453	Raytheon Co. Industrial Components Div. Industrial Tube Operation Newton, Mass.
28520	Heyman Mfg. Co. Kenilworth, N. J.	82389	Switchcraft, Inc. Chicago, Ill.
37942	Mallory, P. R., and Co., Inc. Indianapolis, Ind.	82879	Royal Electric Corp. Pawtucket, R. I.
56289	Sprague Electric Co. North Adams, Mass.	84171	Arco Electronics, Inc. Great Neck, N. Y.
71450	CTS Corp. Elkhart, Ind.	84411	Good-All Electric Mfg. Co. Ogallala, Nebr.
71468	Cannon Electric Co. Los Angeles, Calif.	94310	Tru Ohm Products Div. of Model Engineering and Mfg., Inc. Chicago, Ill.
72354	Fast John E. and Co. Chicago, Ill.	99942	Hoffman Electronics Corp. Semiconductor Division El Monte, Calif.
72699	General Instrument Corp. Newark, N. J.	93656	Electric Cord Co. Caldwell, N. J.
72765	Drake Mfg. Co. Chicago, Ill.		



